

DOMINO

SCREEN FRAME

The **DOMINO FRAME** system is a versatile screen support solution. The system can be suspended, self-supported, wall mounted or attached to any structure. In fact, the Domino can be crafted into virtually any configuration, shape and size imaginable. The screen surface can be wrapped around the structure for a frameless look, or masked for a neatly outlined image. The sturdy steel design is safe, easy to install and can be moved when not in use. Ideal solution for theatres, live venues and broadcast applications. Available with any **Strong | MDI** front or rear projection screen surface.

Applications include: Theatres, live venues, educational, worship facilities, broadcast and rental/touring systems.

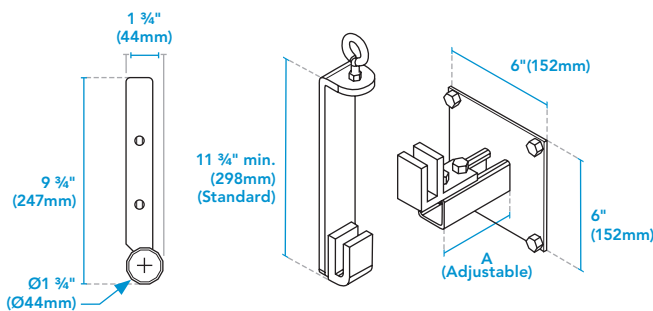

SIDE VIEW

EYEBOLT SUPPORT

WALL MOUNT



FEATURES

- ▶ Steel structure, black finish 1 3/4" (44mm) deep
- ▶ Wrap around screen
- ▶ Bolted frame sections
- ▶ Quick and easy installation
- ▶ Easy to move
- ▶ No size limit for front projection
- ▶ Up to 32' (9.7m) wide for rear projection
- ▶ 2.4 lb per linear ft (3.57 kg per linear meter) 10.8 lb (4.9 kg) total for 4 corners

OPTIONS

- ▶ Available curved or flat
- ▶ Attached to a structure, leg support system, wall mount or ceiling suspension
- ▶ Speaker platforms
- ▶ Available with any **Strong | MDI** screen surface



MDI

1 877 755-3795
info@strongmdi.com
www.strongmdi.com