

# RECESSED INTEGRATED CYBER SERIES

## MOTORIZED SCREEN SYSTEMS

### RECESSED CEILING MOTORIZED SCREEN SYSTEM

uses a separated casing patent technology to reduce noise and vibration. The sturdy and easy to install hidden recessed screen is the ideal solution for applications requiring an attractive and practical screen that blends harmoniously into any decor.

*Applications include: Home cinema, conference rooms, offices, classrooms.*

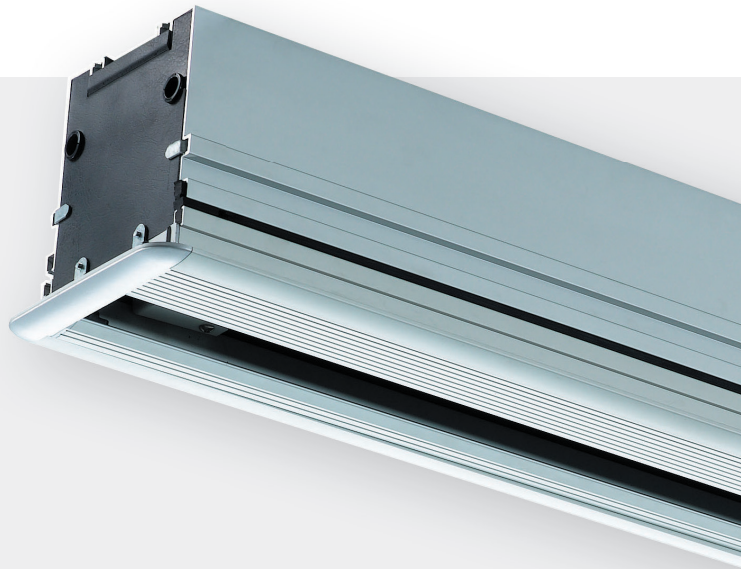

#### FEATURES

- ▶ Separated casing patented technology reduces noise
- ▶ Sturdy and lightweight aluminum alloy construction
- ▶ Available for all ceiling types
- ▶ Enhanced heavy duty tubular motor
- ▶ Adjustable drop/retraction limit
- ▶ Generous amount of black drop
- ▶ 4 layer matte white material with fibreglass backing
- ▶ Built-in control center
- ▶ IR remote control system
- ▶ 12v trigger plug-in
- ▶ RS/232 central command
- ▶ External IR interface
- ▶ Built in switch

#### OPTIONS

- ▶ Available screen surfaces: 1.0, 1.0+, Rearview, Studioview, Blackview (see screen specification for details)
- ▶ Standard, micro or non-perforated screen option
- ▶ Other sizes available upon request
- ▶ Available in 4:3 format



1 877 755-3795  
[info@strongmdi.com](mailto:info@strongmdi.com)  
[www.strongmdi.com](http://www.strongmdi.com)

Format 16:9		RCB-MIR106	RCB-MIR120	RCB-MIR135	RCB-MIR150
Diagonal	in / cm	106 / 269	120 / 305	135 / 343	150 / 381
Viewing area H x W	in cm	52 x 92 132 x 234	59 x 105 150 x 267	66 x 118 168 x 300	74 x 131 188 x 333
L	in / cm	109 / 277	121 ¼ / 308	133 / 338	147 ½ / 375
B1	in / cm	2 / 5		3 / 8	
B2	in / cm	2 / 5		3 / 8	
B3	in / cm	19 ¾ / 50	15 ¾ / 40	11 ¾ / 30	
Weight	lbs / kgs	63 / 29	71 / 32	82 / 37	90 / 41

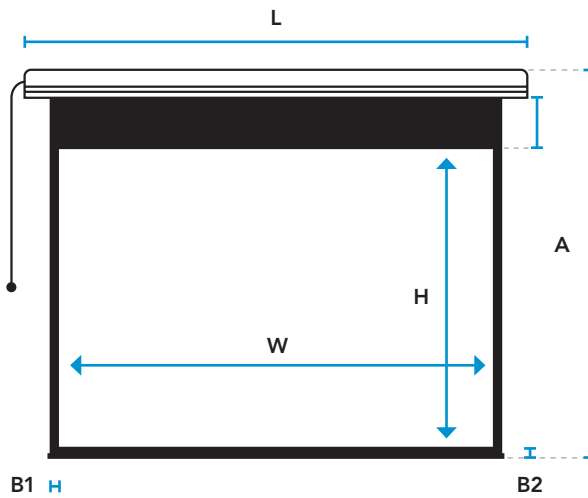

FRONT VIEW

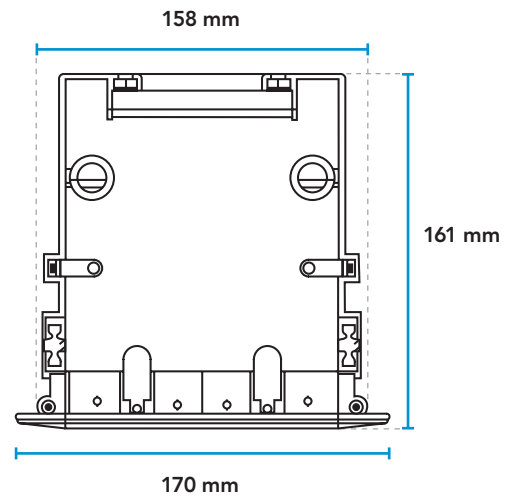

END-CAP VIEW



1 877 755-3795  
[info@strongmdi.com](mailto:info@strongmdi.com)  
[www.strongmdi.com](http://www.strongmdi.com)